

MP80

Micro Pitch Modular Belt Series

MP80 C

MP80 FG

MP80 NS (Non-Slip)

MP80 NP (Negative Pyramid)

Sprockets

Engineering Information

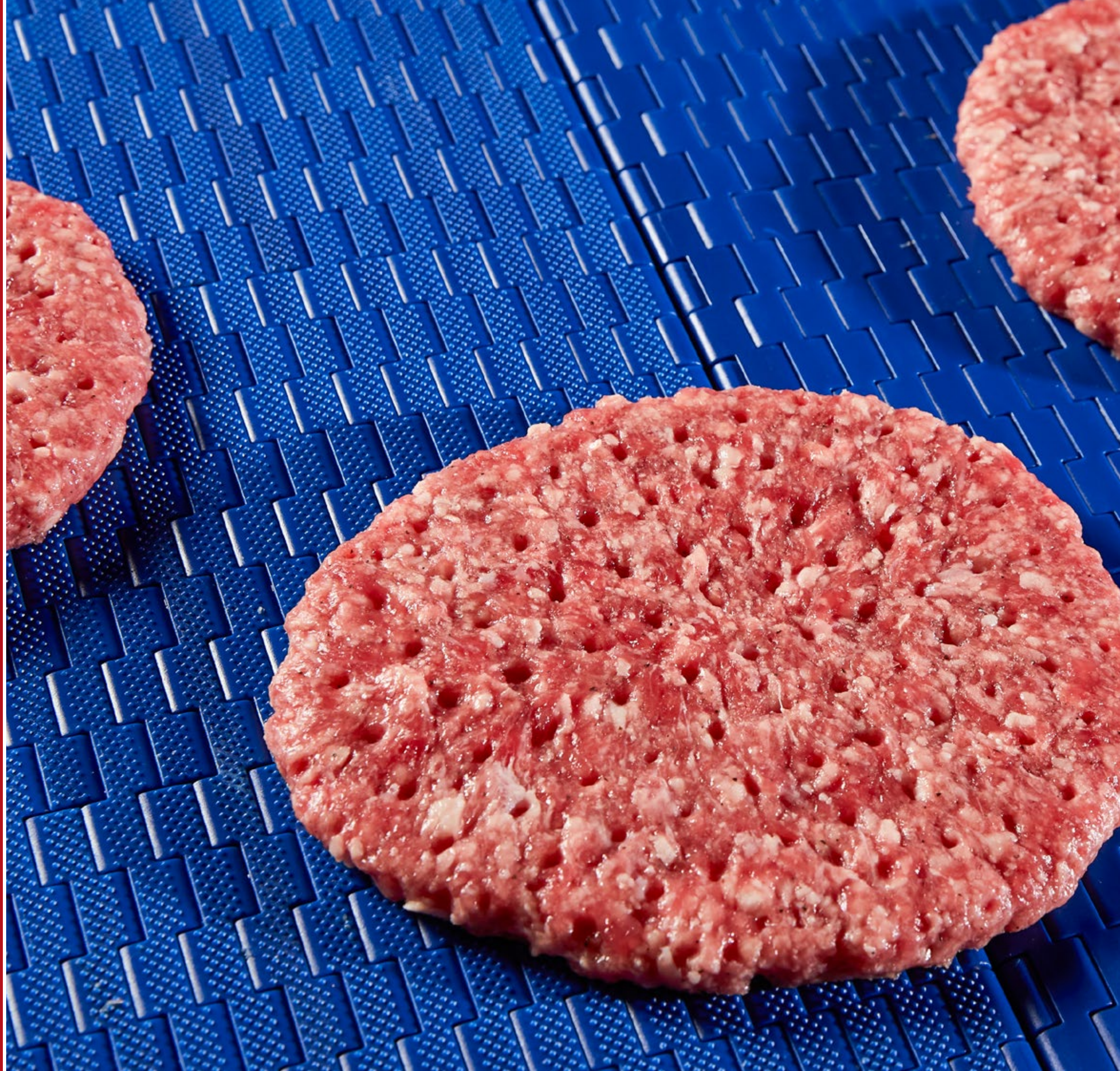



MP80 C

Pitch:	8 mm / 0.315 inch
Belt Surface:	Close, Smooth Surface
Minimum Width:	101,6 mm / 4 inch
Open Area (%):	0%
Flight:	No
Sidewall:	No
Rod:	Ø3 mm / 0.118 inch
Approved:	FDA and EU
Curve:	No
Color:	Additional colors available
Cleanability:	Good
Belt Thickness:	6 mm / 0.236 inch
Min. Nosebar Diameter:	6 mm / 0.236 inch

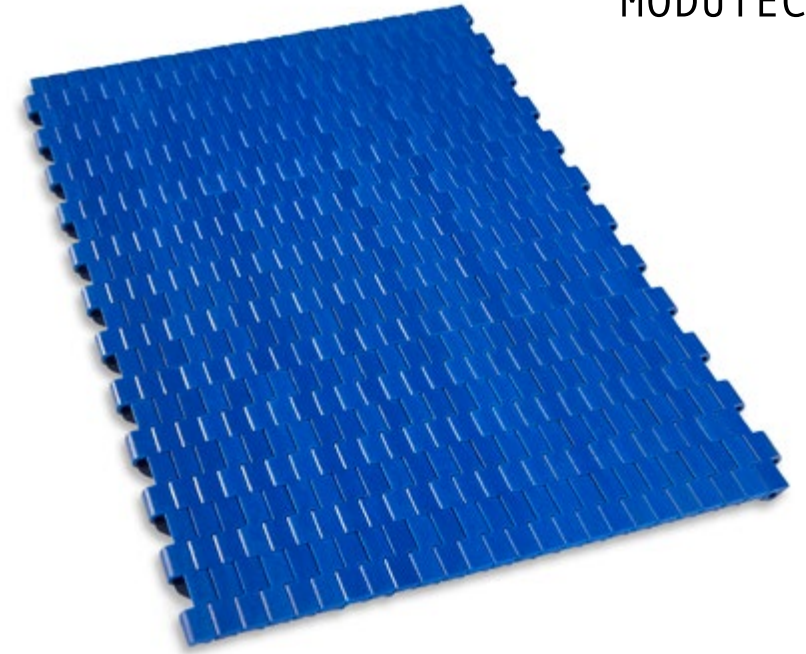

Product Features and Functional Benefits

- Micro pitch series with small transfer gaps for tight transfer.
- Designed to run over 6 mm nosebars or rollers.
- Belt and sprocket design ensures superior load transmission and belt pull capacity.
- Headless pin making it very easy to install and remove the belt for maintenance.

Available Moulded Module Sizes

- 203,2 mm / **8 inch** module
- 101,6 mm / **4 inch** module

MP80 C

Micro Pitch Modular Belt Series

• Bakery Applications

Row Dough Handling, Divider, Proofer Lines, Laminating Lines

• Meat Applications

Transfer - Crossover Conveyance and Metal Detectors

• Seafood Applications

Grading Lines and Weighing Lines

• Fruits and Vegetables Applications

Control and Sorting Tables

• Snack Food Applications

Cooling Lines

• Beverage Applications

Box Transfer

MP80 C / Technical Information

BELT / PIN MATERIAL	BELT STRENGTH				TEMPERATURE		BELT WEIGHT
	Straight		Curve		°C / °F (min.)	°C / °F (max.)	Kg/m ² / lb/ft ²
	N/m	lb/ft	N/m	lb/ft			
Acetal / Acetal	2750	188	-	-	-43 / -45.4	+110 / +230	5,3 / 1.09

- Belt strength and temperature values are maximum on the table.

MP80 C / Standard Belt Widths

BELT SERIES	WIDTH (W)				Belt With Tolerance (max.)
	PP-PE		POM		
	mm	inch	mm	inch	
MP80 C	-	-	101,6	4.0	± 1 mm
MP80 C	-	-	203,2	8.0	± 1 mm
MP80 C	-	-	304,8	12.0	± 1 mm
MP80 C	-	-	406,4	16.0	± 1 mm
MP80 C	-	-	508,0	20.0	± 2 mm
MP80 C	-	-	609,6	24.0	± 2 mm
MP80 C	-	-	711,2	28.0	± 2 mm
MP80 C	-	-	812,8	32.0	± 2 mm
MP80 C	-	-	914,4	36.0	± 2 mm

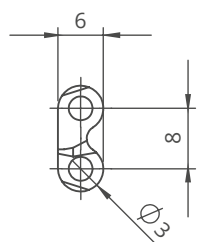
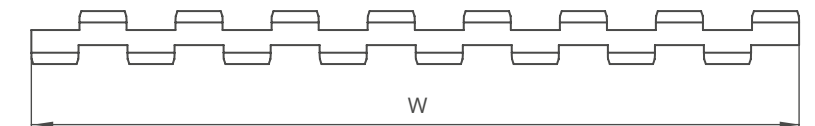

- Standard belt increments 101,6 mm.
- Non-standard belt increments 25,4 mm.
Please contact with customer service for precise belt measurements.

MP80 FG

Pitch:	8 mm / 0.315 inch
Belt Surface:	Open, Smooth Surface
Minimum Width:	101,6 mm / 4 inch
Open Area (%):	34%. (Biggest opening 6,5 x 13 mm)
Flight:	No
Sidewall:	No
Rod:	Ø3 mm / 0.118 inch
Approved:	FDA and EU
Curve:	No
Color:	Additional colors available
Cleanability:	Good
Belt Thickness:	6 mm / 0.236 inch
Min. Nosebar Diameter:	6 mm / 0.236 inch

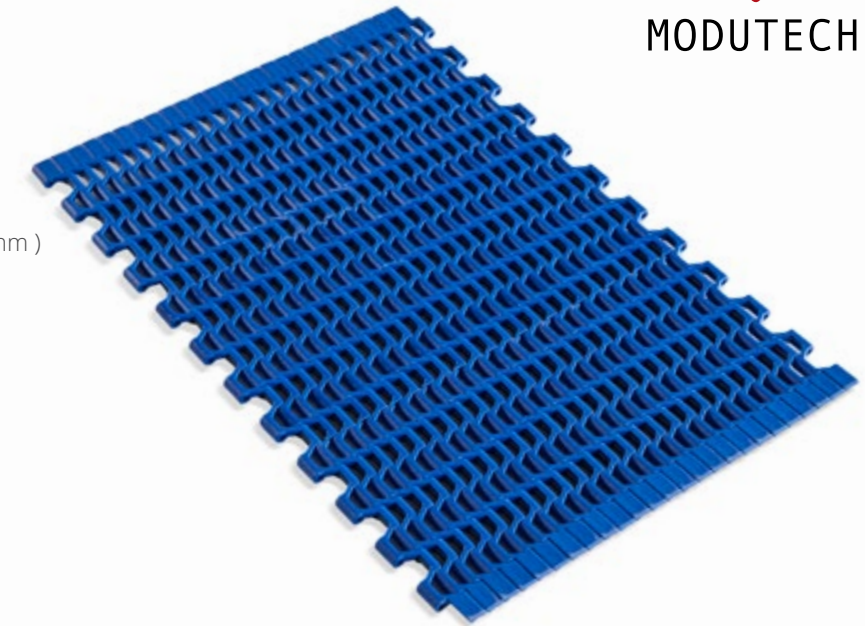

Product Features and Functional Benefits

- Micro pitch series with small transfer gaps for tight transfer.
- Designed to run over nosebars/knife edges or rollers with a radius down to 3mm (**0.12 inch**) allowing, precise transfer of even the smallest products.
- Versatile for conveying, drying and cooling applications.
- Optimal design of sprocket teeth, and belt underside provides superior sprocket engagement, safe belt tracking and favorable cleanability.
- Headless pin making it very easy to install and remove the belt for maintenance.

Available Moulded Module Sizes

- 203,2 mm / **8 inch** module
- 101,6 mm / **4 inch** module

MP80 FG / Technical Information

BELT / PIN MATERIAL	BELT STRENGTH				TEMPERATURE		BELT WEIGHT
	Straight		Curve		°C / °F (min.)	°C / °F (max.)	Kg/m ² / lb/ft ²
	N/m	lb/ft	N/m	lb/ft			
Acetal / Acetal	2650	181	-	-	-43 / -45.4	+110 / +230	4,4 / 0.90

- Belt strength and temperature values are maximum on the table.

MP80 FG / Standard Belt Widths

BELT SERIES	WIDTH (W)				Belt With Tolerance (max.)
	PP-PE		POM		
	mm	inch	mm	inch	
MP80 FG	-	-	101,6	4.0	± 1 mm
MP80 FG	-	-	203,2	8.0	± 1 mm
MP80 FG	-	-	304,8	12.0	± 1 mm
MP80 FG	-	-	406,4	16.0	± 1 mm
MP80 FG	-	-	508,0	20.0	± 2 mm
MP80 FG	-	-	609,6	24.0	± 2 mm
MP80 FG	-	-	711,2	28.0	± 2 mm
MP80 FG	-	-	812,8	32.0	± 2 mm
MP80 FG	-	-	914,4	36.0	± 2 mm

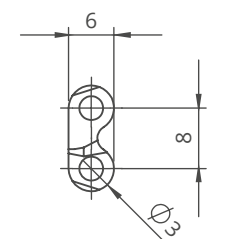
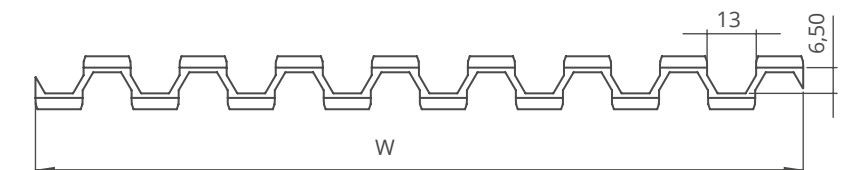

- Standard belt increments 101,6 mm.
 - Non-standard belt increments 25,4 mm.
 Please contact with customer service for precise belt measurements.

MP80 FG

Micro Pitch Modular Belt Series

• Bakery Applications

Row Dough Handling, Divider, Proofer Lines, Laminating Lines

• Meat Applications

Transfer - Crossover Conveyance and Metal Detectors

• Seafood Applications

Grading Lines and Weighing Lines

• Fruits and Vegetables Applications

Control and Sorting Tables

• Snack Food Applications

Cooling Lines

• Beverage Applications

Box Transfer

MP80 NS

Pitch:	8 mm / 0.315 inch
Belt Surface:	Close, Non-Slip Surface
Minimum Width:	101,6 mm / 4 inch
Open Area (%):	0%
Flight:	No
Sidewall:	No
Rod:	Ø3 mm / 0.118 inch
Approved:	FDA and EU
Curve:	No
Color:	Additional colors available
Cleanability:	Good
Belt Thickness:	6,4 mm / 0.252 inch
Min. Nosebar Diameter:	6 mm / 0.236 inch

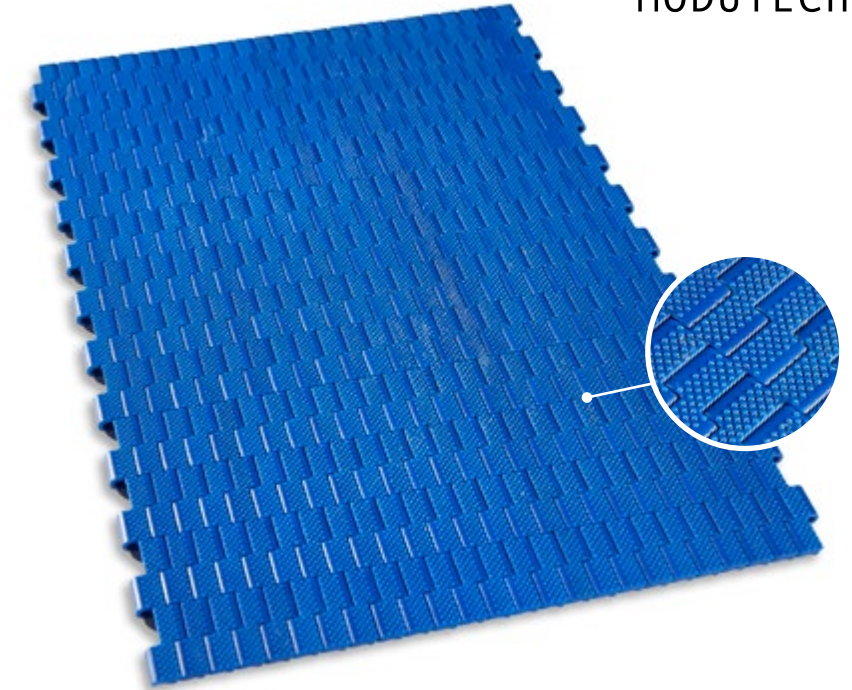

Product Features and Functional Benefits

- Closed surface and pointed studs, cone top surface pattern for superior grip
- Micro pitch series with small transfer gaps for tight transfer.
- Designed to run over nosebars/knife edges or rollers with a radius down to 3mm (**0.12 inch**) allowing, precise transfer of even the smallest products.
- Optimal design of sprocket teeth, and belt underside provides superior sprocket engagement, safe belt tracking and favorable cleanability.
- Headless pin making it very easy to install and remove the belt for maintenance.

Available Moulded Module Sizes

- 203,2 mm / **8 inch** module
- 101,6 mm / **4 inch** module

MP80 NS / Technical Information

BELT / PIN MATERIAL	BELT STRENGTH				TEMPERATURE		BELT WEIGHT
	Straight		Curve		°C / °F (min.)	°C / °F (max.)	Kg/m ² / lb/ft ²
	N/m	lb/ft	N/m	lb/ft			
Acetal / Acetal	2750	188	-	-	-43 / -45.4	+110 / +230	5,3 / 1.09

- Belt strength and temperature values are maximum on the table.

MP80 NS / Standard Belt Widths

BELT SERIES	WIDTH (W)				Belt With Tolerance (max.)
	PP-PE		POM		
	mm	inch	mm	inch	
MP80 NS	-	-	101,6	4.0	± 1 mm
MP80 NS	-	-	203,2	8.0	± 1 mm
MP80 NS	-	-	304,8	12.0	± 1 mm
MP80 NS	-	-	406,4	16.0	± 1 mm
MP80 NS	-	-	508,0	20.0	± 2 mm
MP80 NS	-	-	609,6	24.0	± 2 mm
MP80 NS	-	-	711,2	28.0	± 2 mm
MP80 NS	-	-	812,8	32.0	± 2 mm
MP80 NS	-	-	914,4	36.0	± 2 mm

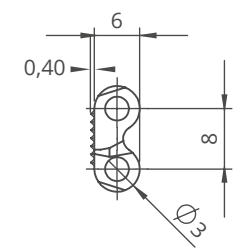
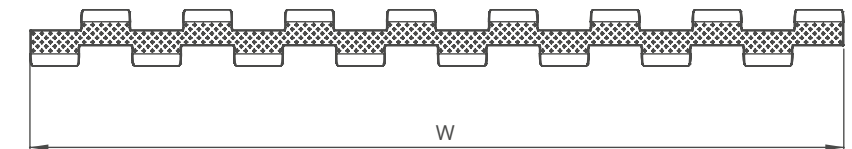

- Standard belt increments 101,6 mm.
 - Non-standard belt increments 25,4 mm.
- Please contact with customer service for precise belt measurements.

MP80 NS

Micro Pitch Modular Belt Series

• Bakery Applications

Row Dough Handling, Divider, Proofer Lines, Laminating Lines

• Meat Applications

Transfer - Crossover Conveyance and Metal Detectors

• Seafood Applications

Grading Lines and Weighing Lines

• Fruits and Vegetables Applications

Control and Sorting Tables

• Snack Food Applications

Cooling Lines

• Beverage Applications

Box Transfer

MP80 NP

Pitch:	8 mm / 0.315 inch
Belt Surface:	Close, Negative Pyramid Surface
Minimum Width:	101,6 mm / 4 inch
Open Area (%):	0%
Flight:	No
Sidewall:	No
Rod:	Ø3 mm / 0.118 inch
Approved:	FDA and EU
Curve:	No
Color:	Additional colors available
Cleanability:	Good
Belt Thickness:	6 mm / 0.236 inch
Min. Nosebar Diameter:	6 mm / 0.236 inch

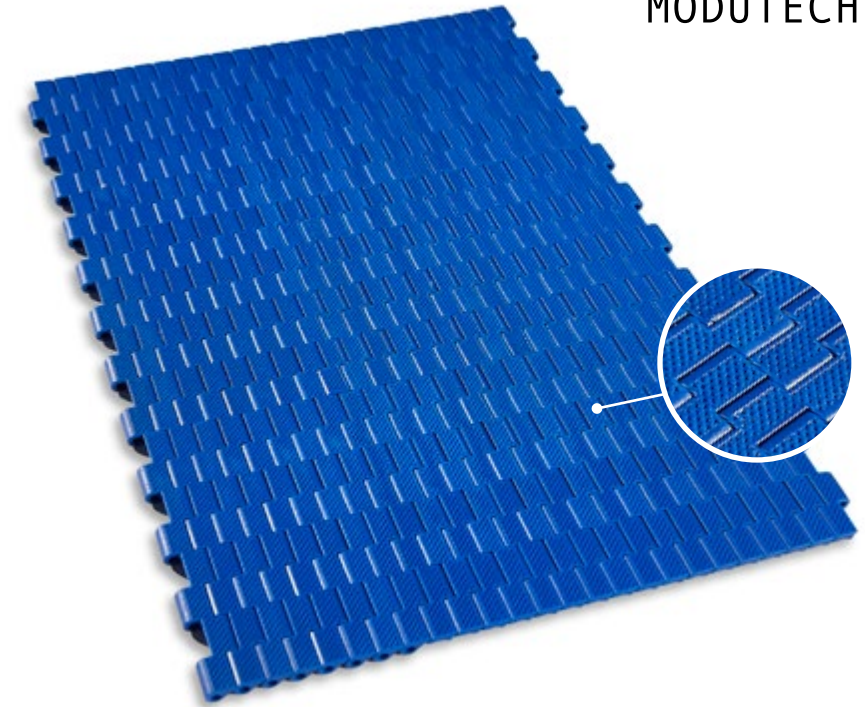

Product Features and Functional Benefits

- Closed surface with inverted pyramid pattern.
- Provides superb release characteristics when conveying wet or sticky products
- Micropitch series with small transfer gaps for tight transfer.
- Designed to run over nosebars/knife edges or rollers with a radius down to 3mm (**0.12 inch**) allowing, precise transfer of even the smallest products.
- Optimal design of sprocket teeth, and belt underside provides superior sprocket engagement, safe belt tracking and favorable cleanability.
- Headless pin making it very easy to install and remove the belt for maintenance.

Available Moulded Module Sizes

- 203,2 mm / **8 inch** module
- 101,6 mm / **4 inch** module

MP80 NP / Technical Information

BELT / PIN MATERIAL	BELT STRENGTH				TEMPERATURE		BELT WEIGHT
	Straight		Curve		°C / °F (min.)	°C / °F (max.)	Kg/m ² / lb/ft ²
	N/m	lb/ft	N/m	lb/ft			
Acetal / Acetal	2750	188	-	-	-43 / -45.4	+110 / +230	5,3 / 1.09

- Belt strength and temperature values are maximum on the table.

MP80 NP / Standard Belt Widths

BELT SERIES	WIDTH (W)				Belt With Tolerance (max.)
	PP-PE		POM		
	mm	inch	mm	inch	
MP80 NP	-	-	101,6	4.0	± 1 mm
MP80 NP	-	-	203,2	8.0	± 1 mm
MP80 NP	-	-	304,8	12.0	± 1 mm
MP80 NP	-	-	406,4	16.0	± 1 mm
MP80 NP	-	-	508,0	20.0	± 2 mm
MP80 NP	-	-	609,6	24.0	± 2 mm
MP80 NP	-	-	711,2	28.0	± 2 mm
MP80 NP	-	-	812,8	32.0	± 2 mm
MP80 NP	-	-	914,4	36.0	± 2 mm

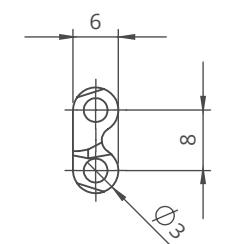
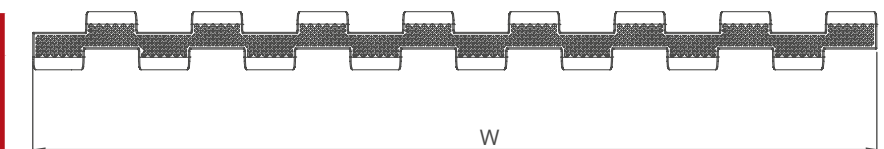

- Standard belt increments 101,6 mm.
 - Non-standard belt increments 25,4 mm.
- Please contact with customer service for precise belt measurements.

MP80 NP

Micro Pitch Modular Belt Series

• Bakery Applications

Row Dough Handling, Divider, Proofer Lines, Laminating Lines

• Meat Applications

Transfer - Crossover Conveyance and Metal Detectors

• Seafood Applications

Grading Lines and Weighing Lines

• Fruits and Vegetables Applications

Control and Sorting Tables

• Snack Food Applications

Cooling Lines

• Beverage Applications

Box Transfer

Micro Pitch Modular Belt Series

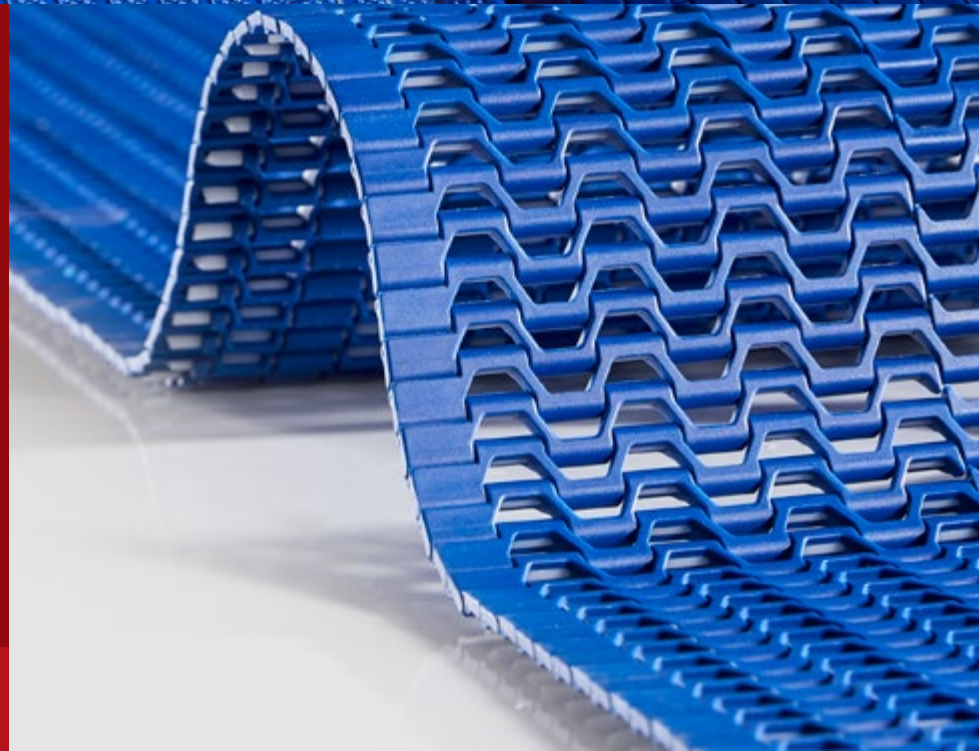
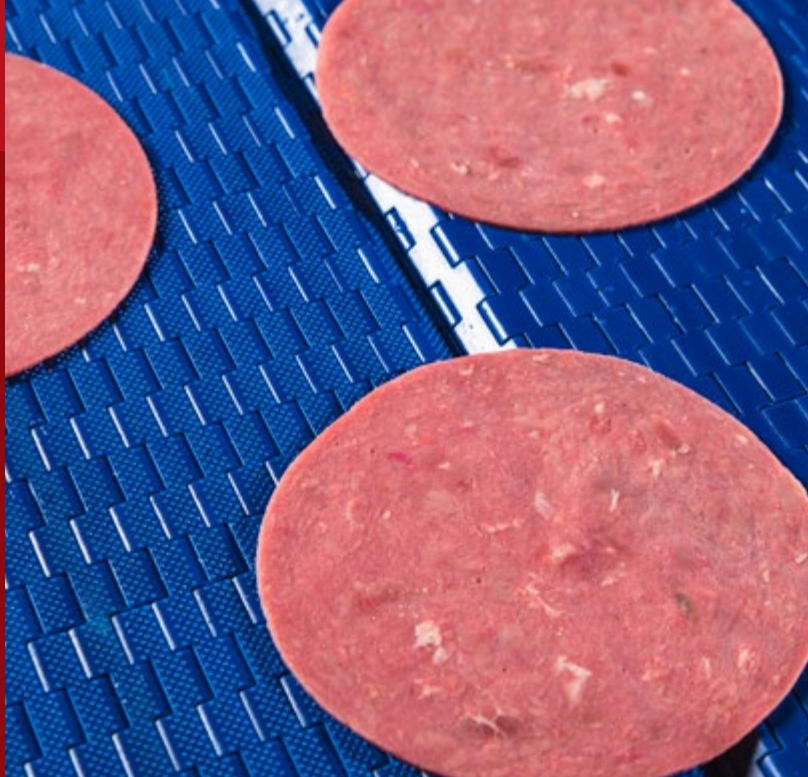

MP80 (Micro Pitch Series) Technical Specifications



Z36

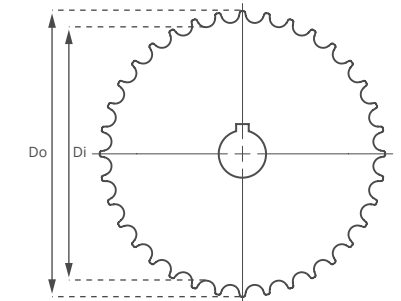
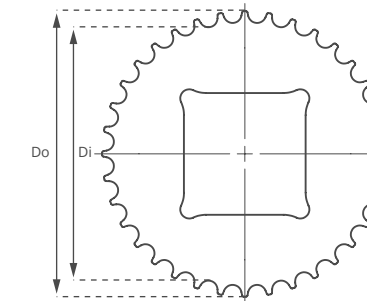

MP80 Micro Pitch Series / Machined Sprockets Dimensions

NO. TEETH	Di mm/inch	Do mm/inch	B mm/inch	A mm/inch	Square Bore (Q) mm/inch	Round Bore (R) mm/inch	PRODUCT CODE	
							Square Type (Q)	Round Type (R)
Z18	40,9 / 1.61	48,0 / 1.89	6 / 0.23	20 / 0.78	20 / 0.78	25 / 1	MP80SQZ18	MP80SRZ18
Z24	56,4 / 2.22	63,7 / 2.51	6 / 0.23	20 / 0.78	25 / 1	25-30 / 1-1.25	MP80SQZ24	MP80SRZ24
Z36	87,5 / 3.44	94,9 / 3.74	6 / 0.23	20 / 0.78	40 / 1.57	25-30 / 1-1.25	MP80SQZ36	MP80SRZ36

*All required sprockets produced by CNC.
 *Other sprockets and hub sizes are manufactured up to request.
 *POM (Acetal) and PA (Polyamide) sprockets raw material is available on request.
***Machined Split Sprockets are available for each size.**



Precise transfer even the smallest products!
 Micropitch belt series are suitable to run 6 mm nosebar roller.



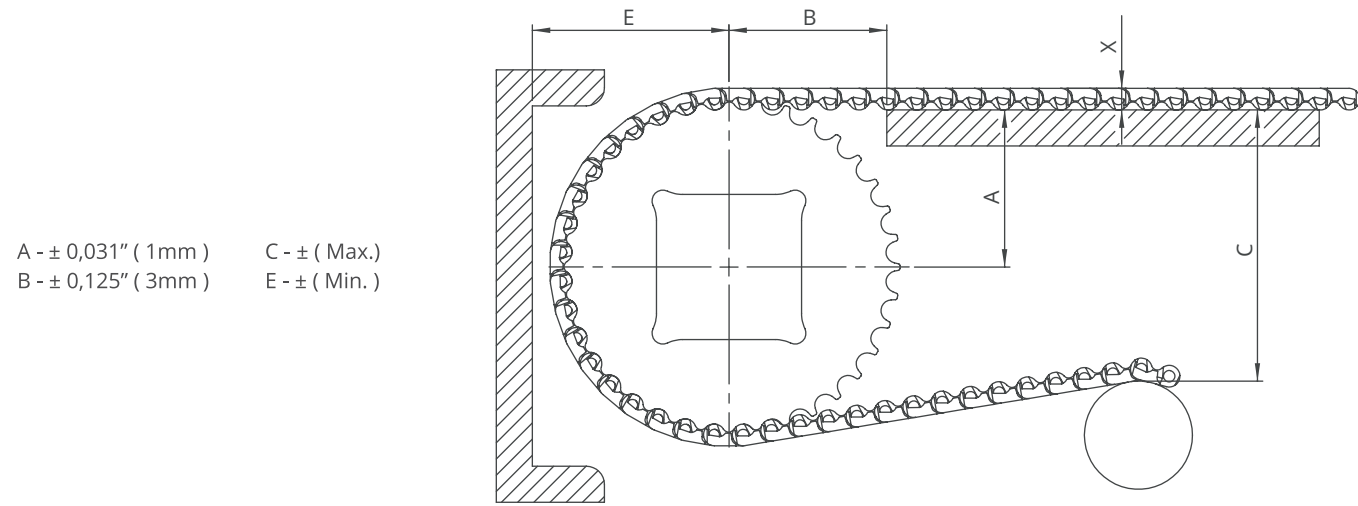

A - ± 0,031" (1mm) C - ± (Max.)
 B - ± 0,125" (3mm) E - ± (Min.)

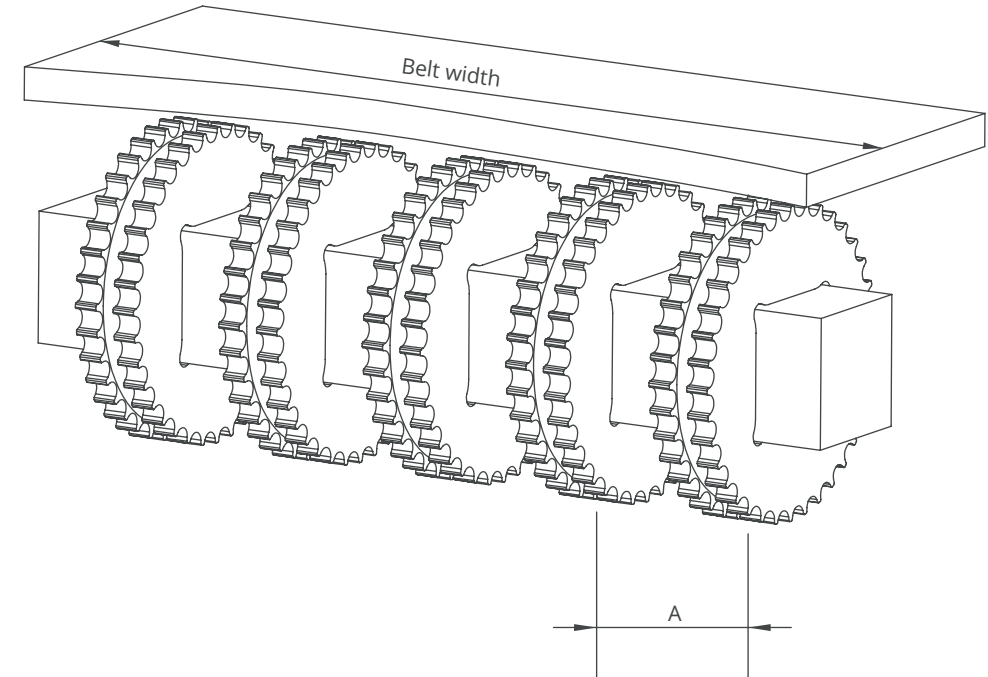

MP80 Series / Conveyor Frame Dimensions

Sprockets Description			A		B		C		E		X	
Pitch Diameter		No.Teeth	Range (Bottom to Top)		Inch	mm	Inch	mm	Inch	mm	Inch	mm
Inch	mm		Inch	mm								
MP80 C, MP80 FG, MP80 NP, MP80 NS												
1.85	47,0	18	0.81	20,5	1.18	30,0	1.12	28,5	1.24	31,5	0.24	6,0
1.95	49,5	24	1.11	28,3	1.38	35,0	1.73	44,0	1.55	39,3	0.24	6,0
3.68	93,5	36	1.72	43,8	1.77	45,0	2.95	75,0	2.16	54,8	0.24	6,0

MP80 Series / Sprockets Arrangement

Standard Belt Width		Number of sprockets per shaft		A (mm/inch)	
mm	inch	Drive Shaft	Return Shaft	Min.	Max.
101,6	4.0	2	2	50/2	100/4
203,2	8.0	3	2	50/2	100/4
304,8	12.0	4	3	50/2	100/4
406,4	16.0	5	3	50/2	100/4
508,0	20.0	6	4	50/2	100/4
609,6	24.0	7	5	50/2	100/4
711,2	28.0	8	6	50/2	100/4
812,8	32.0	9	7	50/2	100/4
914,4	36.0	10	8	50/2	100/4
1016,0	40.0	11	9	50/2	100/4
1117,6	44.0	12	9	50/2	100/4
1219,2	48.0	13	10	50/2	100/4
1320,8	52.0	14	11	50/2	100/4
1422,4	56.0	14	11	50/2	100/4
1524,0	60.0	15	12	50/2	100/4
1625,6	64.0	16	12	50/2	100/4

MP80 Series / Slider Support System For Straight Running Belts

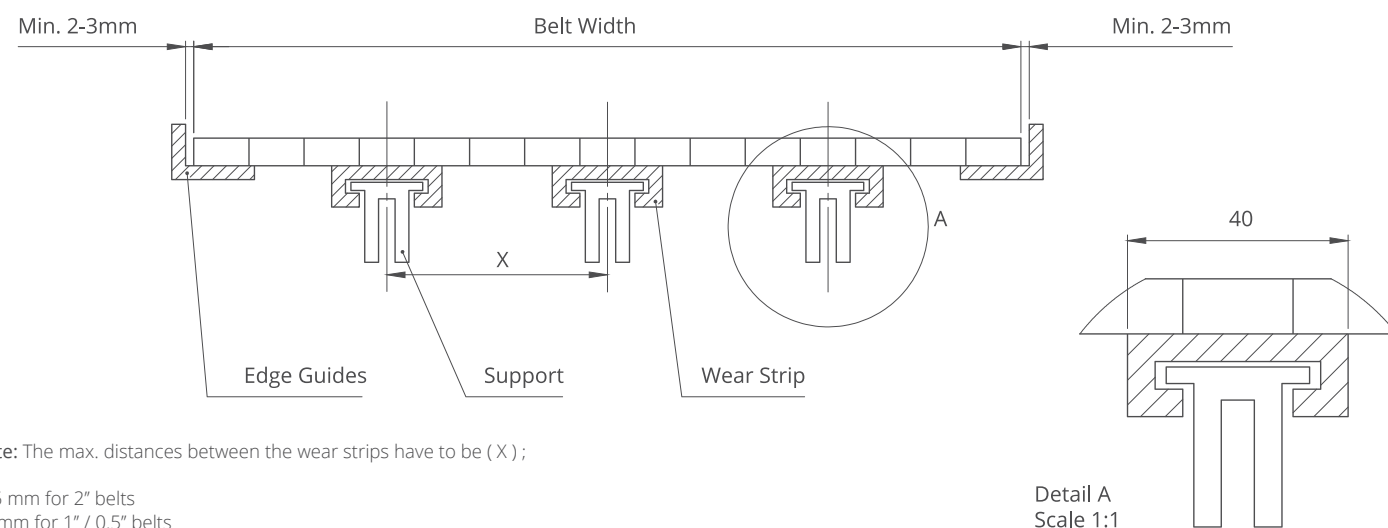

Note: The max. distances between the wear strips have to be (X);

125 mm for 2" belts
 80 mm for 1" / 0.5" belts

Detail A
 Scale 1:1