

Basic device – SNO 4083KM

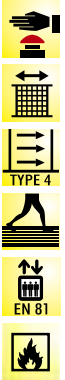

Applications

- Protection of people and machinery
- Monitoring of emergency stop applications
- Monitoring of safety gates
- Monitoring of light barriers
- Up to PL e/Categorie 4 (EN ISO 13849-1)
- Up to SIL_{CL} 3 (EN 62061)

Features

- Stop Category 0 according to EN 60204-1
- Single-channel or two-channel control
- Two-channel control with NC/NC or NC/NO
- Manual or automatic start
- Cross monitoring
- Synchronous time monitoring for two-channel control
- 3 enabling current path / 1 signalling current path

Function

After the supply voltage is applied to terminals A1/A2 and the safety inputs are closed, the enabling current paths (NO contacts) are closed and the signal current path (NC contact) is opened automatically or by pressing the reset button (manual monitored start). When the safety inputs are opened/de-energized the enabling current paths (NO contacts) are opened immediately and the signal current path (NC contact) is closed.

- **Reduced installation work** – The SNO 4083KM requires fewer connection cables, irrespective of whether operation with or without cross monitoring is desired. This saves time and money when it comes to wiring.
- **Universal application** – The two-channel control of the device is carried out by either an NC/NC or an NC/NO combination of the safety sensor. In the case of two-channel control of the device, a synchronous time is automatically monitored between the two channels.

- **SafeStart function** – When the device is used with a manual start, the reset input is automatically monitored for a rising and falling signal edge. A manual reset signal is only accepted if the control inputs of the device are activated by the safe transducer (e.g. emergency stop button) during the entire activation procedure.
- **Monoflop function** – This function is integrated into the device and prevents device interlocking under all circumstances. This is a decisive advantage in applications where very short interruptions of the safety-related signals can occur, or in the case of transducers with bouncing contacts or safe optical sensors (BWS), for example.
- **Simple diagnosis** – The device features an intelligent display system that shows the user the different operating modes of the device in its different applications. This means, for example, that when the control inputs are closed and manual start has been selected, a reset signal is displayed, which has not yet been given. Fault states in the control (e.g. synchronous time exceeded or a short-circuit in two-channel control) are also signaled to the user via a blinking code.

Circuit diagram

SNO 4083KM

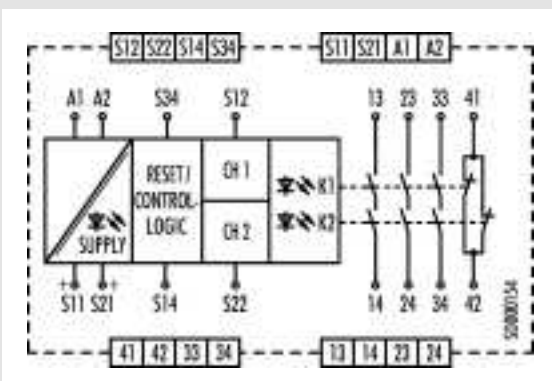

Basic device – SNO 4083KM

Overview of devices | part numbers

Type	Rated voltage	Synchr. Time	Terminals	Part no.	Std. pack
SNO 4083KM-A	24 V DC	1.5 s	Screw terminals, pluggable	R1.188.3580.0	1
SNO 4083KM-A	115-230 V AC	1.5 s	Screw terminals, pluggable	R1.188.3590.0	1
SNO 4083KM-C	24 V DC	1.5 s	Cage clamp, pluggable	R1.188.3600.0	1
SNO 4083KM-C	115-230 V AC	1.5 s	Cage clamp, pluggable	R1.188.3610.0	1
SNO 4083KM-A	24 V DC	0.5 s	Screw terminals, pluggable	R1.188.3830.0	1
SNO 4083KM-A	115-230 V AC	0.5 s	Screw terminals, pluggable	R1.188.3840.0	1
SNO 4083KM-C	24 V DC	0.5 s	Cage clamp, pluggable	R1.188.3850.0	1
SNO 4083KM-C	115-230 V AC	0.5 s	Cage clamp, pluggable	R1.188.3860.0	1

Technical data

Function	Emergency stop relay		
Function display	3 LEDs, green		
Power supply circuit			
Rated voltage U_N	A1, A2	24 V DC/ 115-230 V AC	
Rated consumption	24 V DC	1.6 W	
	115-230 V AC	1.8 W / 4.0 VA	
Rated frequency	50 - 60 Hz		
Operating voltage range U_B	0.85 - 1.1 x U_N		
Electrical isolation supply circuit - control circuit	yes (at $U_N = 115-230$ V AC)		
Control circuit			
Rated output voltage	S11/S21	22.5 V DC	
Input current / peak current	S12, S22	25 mA / 100 mA	
	S14, S34	3 mA / 5 mA	
Response time t_{A1} / t_{A2}	250 ms		
Minimum ON time t_M	60 ms		
Recovery time t_w	120 ms		
Release time t_R	20 ms		
Synchronous time t_s	0.5 s / 1.5 s		
Permissible test pulse time t_{TP}	< 0,8 ms		
Max. resistivity, per channel ¹⁾	24 V DC	$\leq (5 + (1.176 \times U_B / U_N - 1) \times 100) \Omega$	
	115-230 V AC	$\leq 12 \Omega$	
Output circuit			
Enabling paths	13/14, 23/24, 33/34	normally open contact	
Signaling paths	41/42	normally closed contact	
Contact assignment	forcefully guided		
Contact type	Ag-alloy, gold-plated		
Rated switching voltage	enabling / signaling path	230 V AC	
Max. thermal current I_{th}	enabling / signaling path	6 A / 2 A	
Max. total current I^2 of all current path	($T_u = 55$ °C) / ($T_u = 65$ °C)	25 A ² / 9 A ²	
Application category (NO)	AC-15	U_o 230V, I_o 5 A	
	DC-13	U_o 24V, I_o 5A	
Short-circuit protection (NO), lead fuse / circuit breaker	6 A class gG / melting integral < 100 A ² s		
Mechanical life	10 ⁷ switching cycles		
General data			
Creepage distances and clearances between the circuits	EN 60664-1		
Protection degree according to DIN EN 60529 (housing / terminals)	IP40 / IP20		
Ambient temperature / storage temperature	-25 °C - +65 °C / -25 °C - + 75 °C		
Wire ranges screw terminals,	fine-stranded / solid	1 x 0.14 mm ² – 2.5 mm ² / 2 x 0.14 mm ² – 0.75 mm ²	
	fine-stranded with ferrules	1 x 0.25 mm ² – 2.5 mm ² / 2 x 0.25 mm ² – 0.5 mm ²	
Permissible torque	0.5 - 0.6 Nm		
Wire ranges cage clamp terminals	1 x 0,25 mm ² – 1.5 mm ²		
Weight	24 V AC/DC device / AC device	0.2 kg	
Standards	EN ISO 13849-1, EN 62061, EN 81-1, EN 50156-1		
Approvals	TÜV  (pending)		

¹⁾ If two-channel devices are installed as single channel, the value is halved.